

**AIR SAFE**

## 32K 5<sup>th</sup> Wheel Instructions

**AIR SAFE**

**AIR SAFE™**

**AIR SAFE™**

### Installation

The 32K 5<sup>th</sup> Wheel hitch base is 5/8 steel with slots in each corner for using the Rail Pins (4 that come with hitch) or use bolts (not supplied) through these holes into your truck box. Since the hitch is mounted on 5/8 steel you do not need a solid steel base below. The hitch is 24” wide and will fit between the truck frame of most heavy duty semi truck. The hitch does not require a constant air supply and comes with a standard air fitting.

### Connecting Trailer

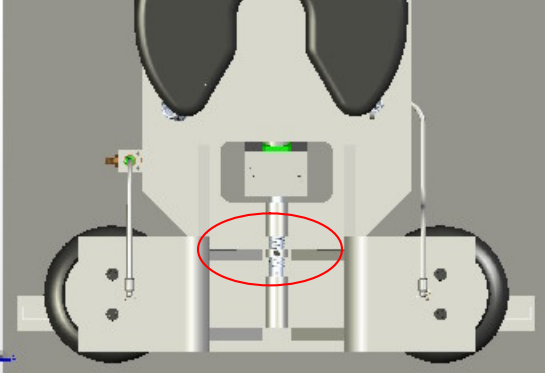
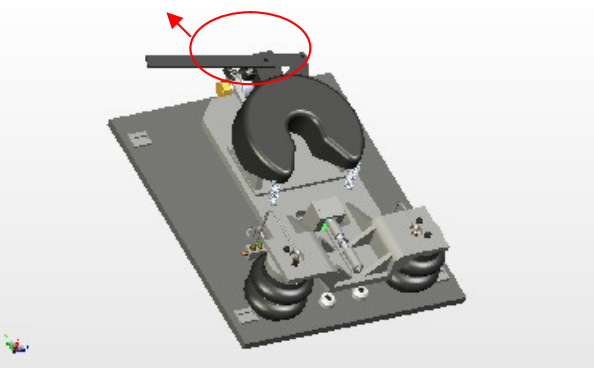
	<p>Hitch is shipped in the locked position. The picture to the left shows the hitch with the red circle showing the locked pin position.</p>
	<p>To set 5<sup>th</sup> wheel jaws for locking, pull handle slightly forward (toward the front of the truck),</p>
	<p>Pull release pin that is under handle.</p>

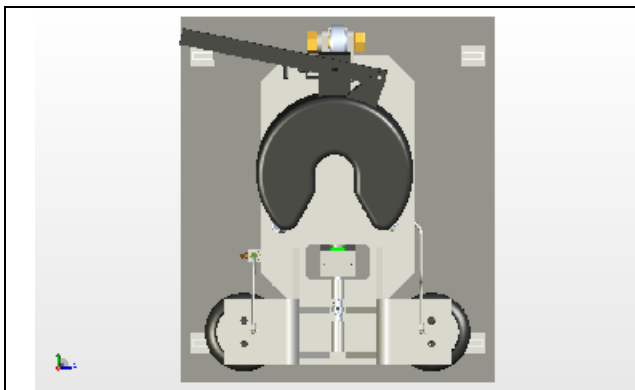

Then release handle until it clears the pin. You are ready to back into kingpin in the normal manner.  
“Always test pull with trailer brakes on before towing trailer”

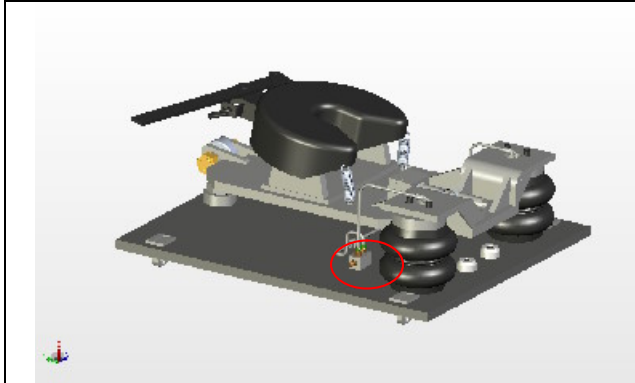

Connect your trailer. Lift your landing legs until trailer is supported only by the hitch.

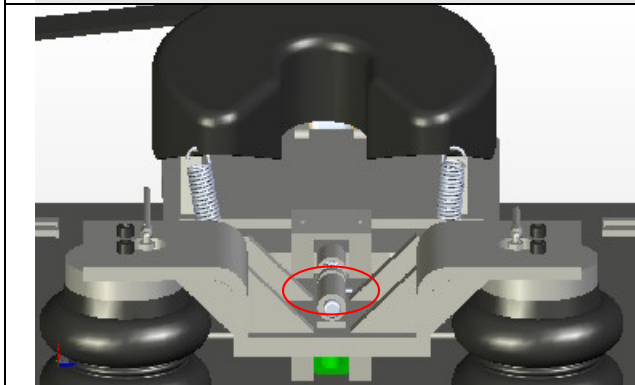

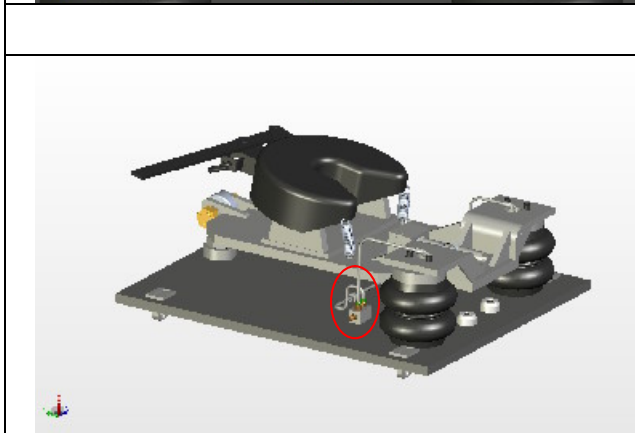

Rotate the locking pin handle from left to right as shown by the picture.



Inflate or deflate the airbags until the pin automatically retracts itself.

You are now at the design ride height.

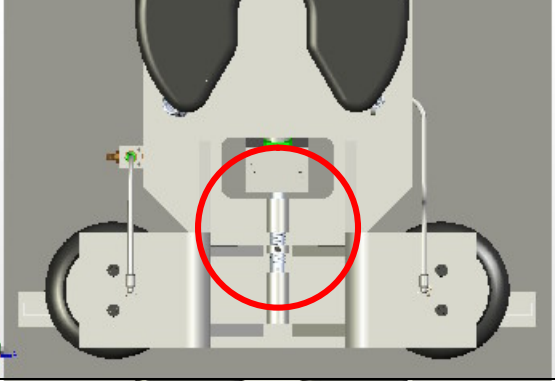
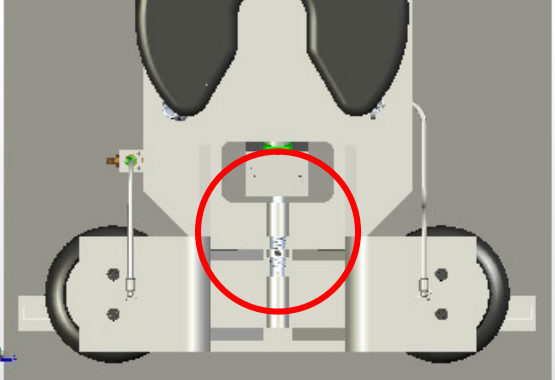
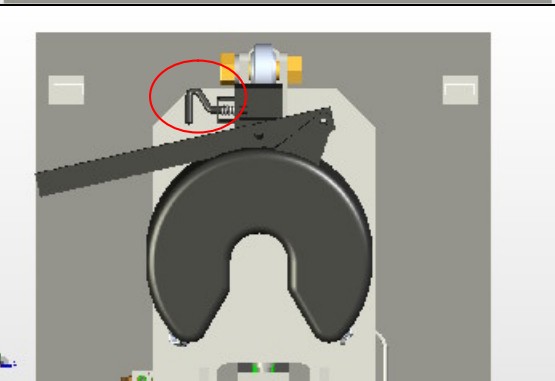
## Disconnecting Trailer

	<p>Push the pin forward.</p>
	<p>Rotate the pin handle from right to left. Drop down landing legs on trailer and take weight off of the hitch.</p>
	<p>Pull release pin that is under the handle</p>
	<p>Pull Handle forward (toward the front of the truck) then release the pin. The handle should lock in the forward position. Unhook all safety chains and light/brake cables, now drive vehicle slowly away from trailer.</p>